

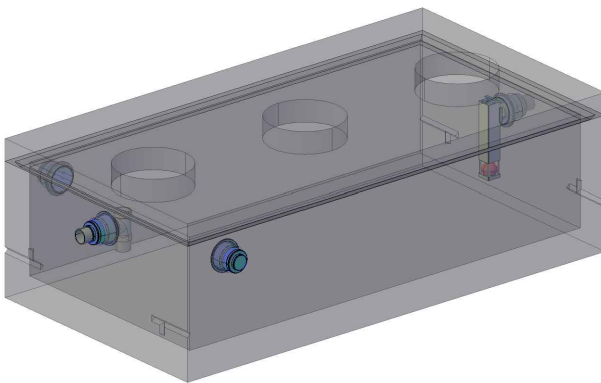

## 38Y 1000GAL LOWBOY SEPTIC TANK

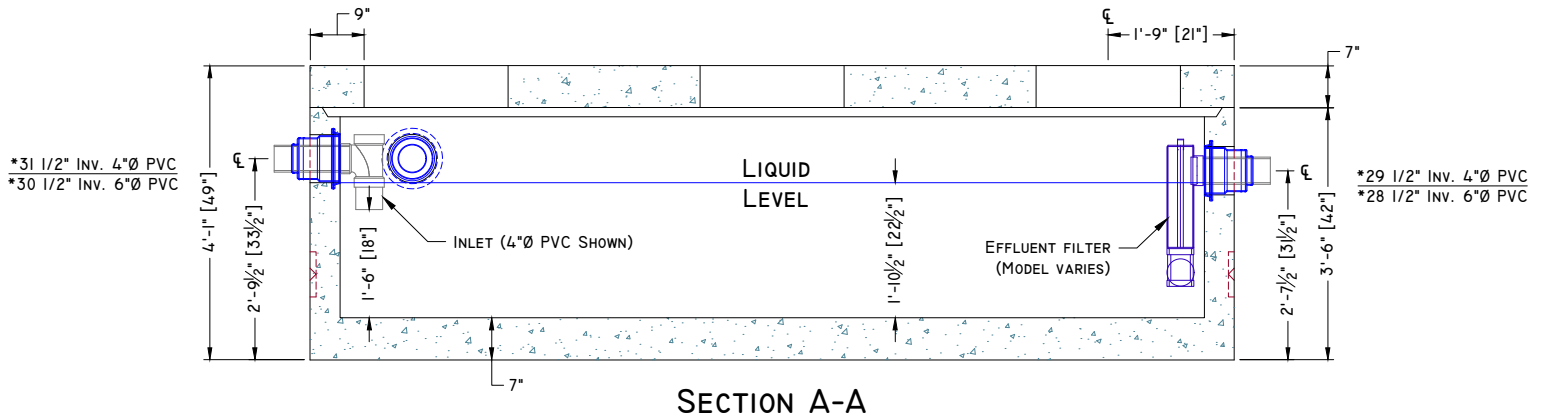
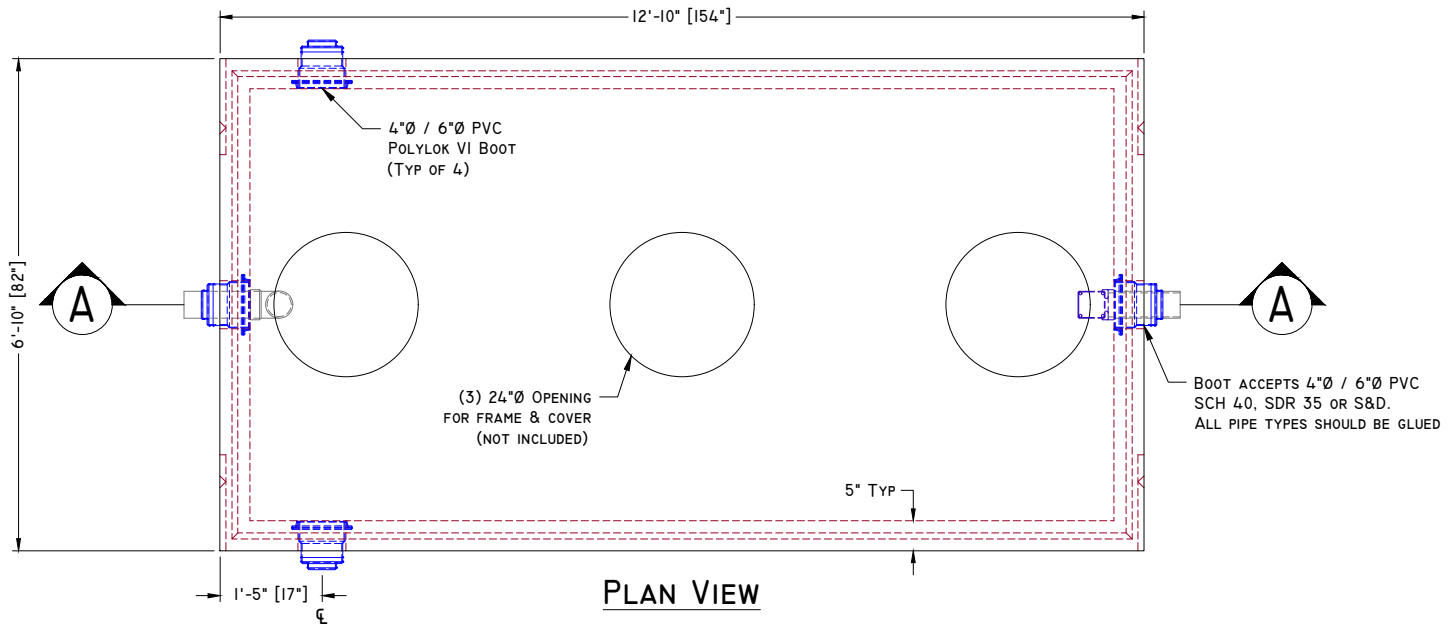

CONCEPTUAL VIEW - NTS

\*Dimension is taken from bottom of tank

### Manufacturing Notes

- 1.1. CONCRETE COMPRESSIVE STRENGTH: 5000PSI @ 28 DAYS
- 1.2. AIR ENTRAINMENT: 4-6%
- 1.3. GRADE 60 REINFORCEMENT
- 1.4. TANKS SHOULD BE PUMPED EVERY 3-5 YEARS, DEPENDING ON USE
- 1.5. NEVER USE SEPTIC CLEANING AGENTS
- 1.6. DESIGNED FOR H2O LOAD RATING
- 1.7. REQUIRES GRADE RINGS TO GRADE & H2O FRAMES & COVERS
- 1.8. ALL TANK PENETRATIONS ARE INTEGRALLY CAST
- 1.9. ALL JOINTS SEALED W/ BUTYL RUBBER JOINT SEALANT

### Physical Specifications:

Cover Weight:	6,995 lbs
Tank Weight:	14,305 lbs
Total Weight:	21,300 lbs
Available Capacity:	1,505 gal (max)
Working Capacity:	1,011 gal (4"Ø PVC) 966 gal (6"Ø PVC)