

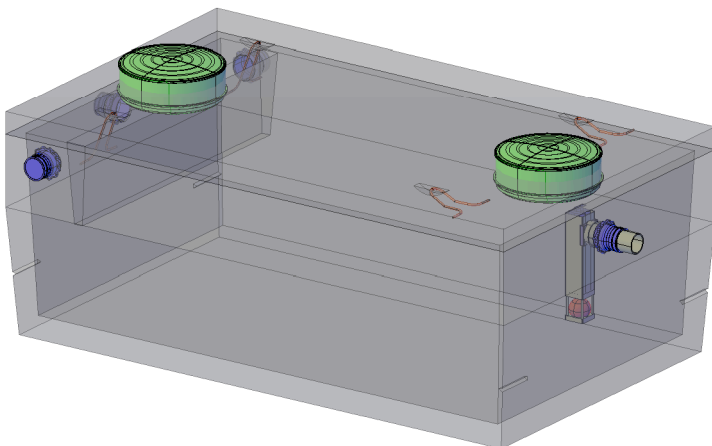

American Concrete Industries

1717 Stillwater Ave. Veazie, ME. 04401

www.americanconcrete.com

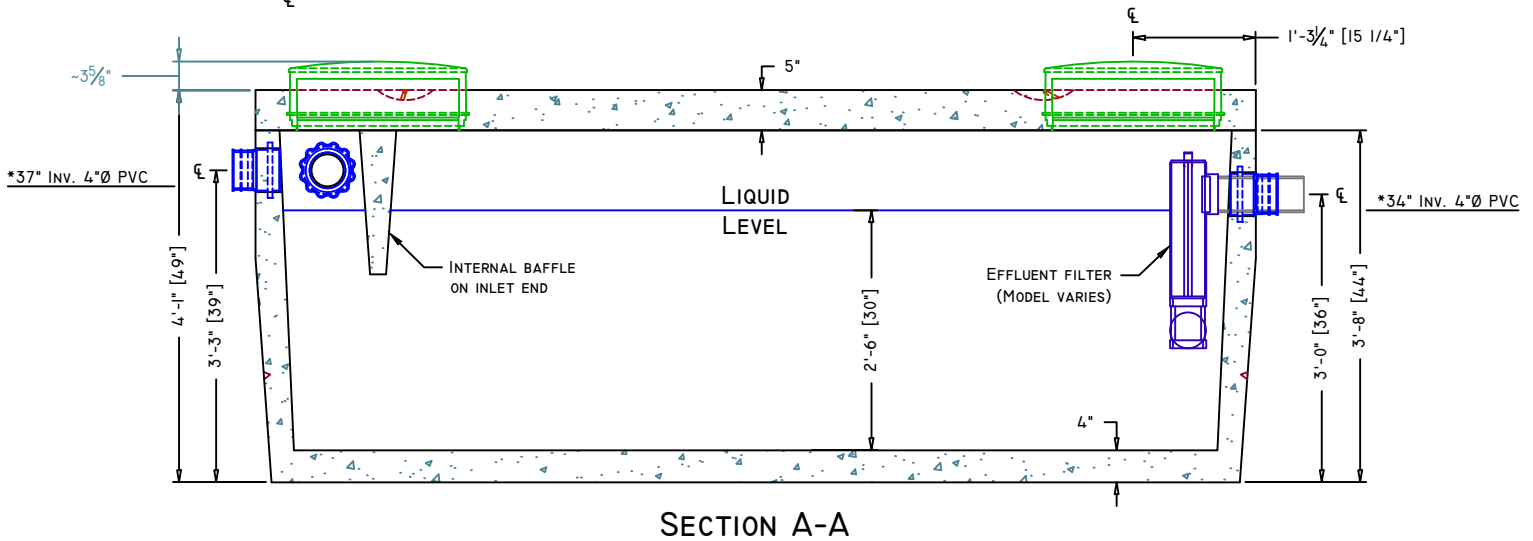
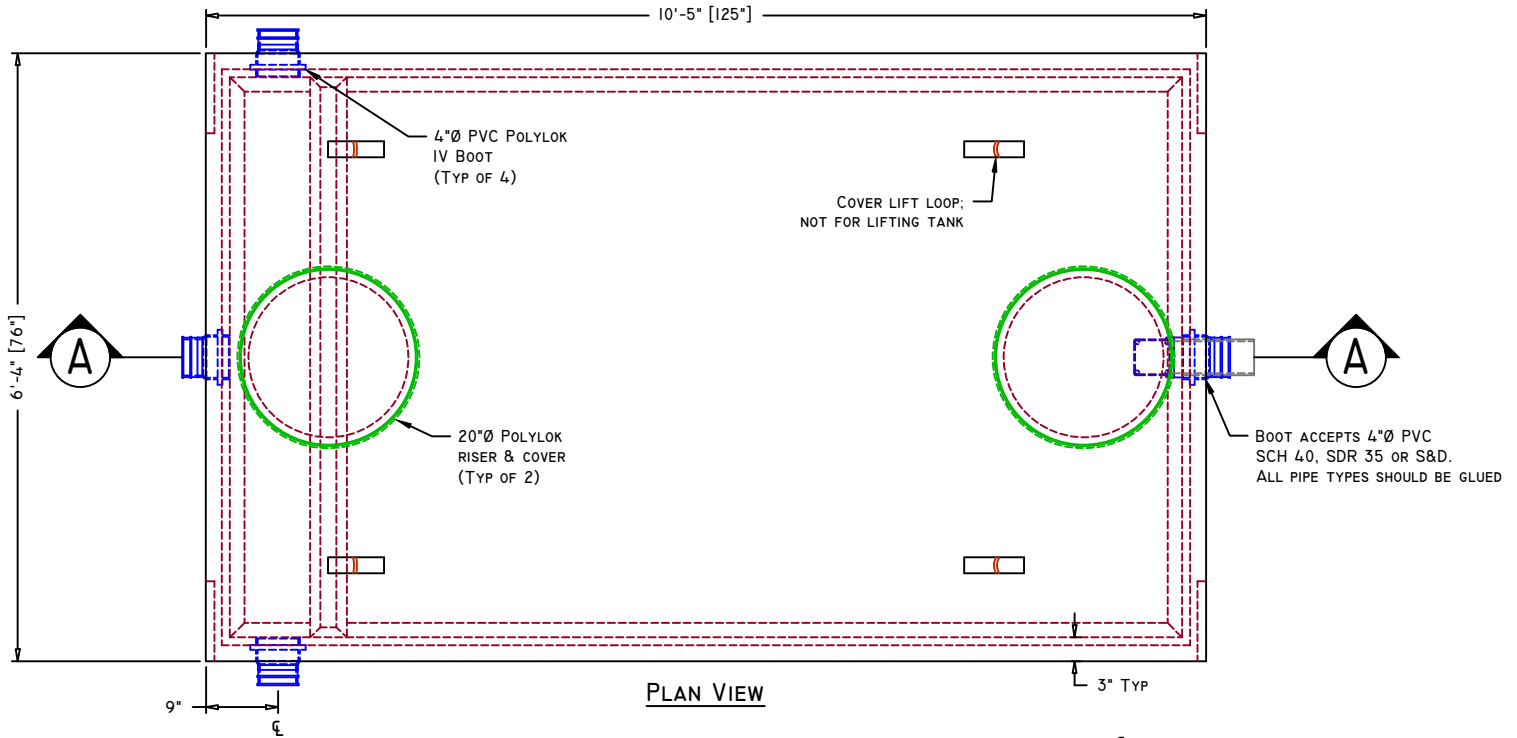

*Dimension is taken from bottom of tank

Manufacturing Notes

- 1.1. CONCRETE COMPRESSIVE STRENGTH: 5000PSI @ 28 DAYS
- 1.2. AIR ENTRAINMENT: 4-6%
- 1.3. GRADE 60 REINFORCEMENT
- 1.4. STRUCTURAL FIBER REINFORCED BASE
- 1.5. TANKS SHOULD BE PUMPED EVERY 3-5 YEARS, DEPENDING ON USE
- 1.6. NEVER USE SEPTIC CLEANING AGENTS
- 1.7. DESIGNED FOR PEDESTRIAN LOAD RATING ONLY
- 1.7.1. SPECIFY H20 FOR BURIAL DEPTHS > 5'
- 1.8. ALL TANK PENETRATIONS ARE INTEGRALLY CAST
- 1.9. ALL JOINTS SEALED W/ BUTYL RUBBER JOINT SEALANT

Physical Specifications:

Cover Weight:	4,200 lbs
Tank Weight:	7,550 lbs
Total Weight:	11,750 lbs
Available Capacity:	1,386 gal (max) W/O Baffle
Working Capacity:	1,022 gal (4"Ø PVC) W/ Baffle

1000GAL LB SEPTIC TANK W/ POLYLOK RISERS & COVERS

ACI CATALOG DRAWINGS

ITEM#: 291070

DRAWN DATE: 05/26/2015

REVISION #:

SCALE: 1/2" = 1'-0" UNLESS OTHERWISE NOTED

REVISION DATE: